

Eclipse Series

RF Technology
rinfo@rftechnology.com.au

SEPTEMBER 2003

PA220 Amplifier Operation and Maintenance Manual

This manual is produced by RF Technology Pty Ltd
10/8 Leighton Place, Hornsby 2077 Australia
Copyright © 2001 RF Technology Pty Ltd

Contents

1	Operating Instructions	4
1.1	Installation	4
1.1.1	Sub-rack Wiring Guidelines	4
1.2	Front Panel Indicators	4
1.3	Internal Adjustments	5
1.4	Amplifier I/O Connections	5
1.4.1	RF Input	5
1.4.2	RF Output	5
1.4.3	25 Pin Connector	6
2	Circuit Description	6
2.1	Amplifiers	6
2.2	Power Splitter / Combiners	7
2.3	Directional Coupler	7
2.4	Low Pass Filter	7
2.5	Power Control Circuits	7
2.6	RF Output Indicator	8
2.7	Over Temperature Protection	8
3	Field Alignment Procedures	8
3.1	Output Power Level	8
3.2	Tuning Procedure	9
4	Specifications	9
4.1	Description	9
4.2	Physical Configuration	10
4.3	Front Panel Indicators and Test Points	10
4.3.1	Indicators	10
4.3.2	Test Points	10
4.4	Electrical Specifications	10
4.4.1	Power Requirements	10
4.4.2	Frequency Range	10
4.5	Antenna Impedance	11
4.6	Output Power	11
4.6.1	Transmit Duty Cycle	11
4.7	Spurious and Harmonics	11
4.8	Heatsink Temperature	11
4.9	ALC Output	11
4.10	Connectors	11
4.10.1	RF Input	11
4.10.2	RF Output	12
4.10.3	25-Pin Connector	12
4.10.4	9-Pin Connector	12

A	Engineering Diagrams	12
A.1	Block Diagram	12
A.2	Circuit Diagrams	12
A.3	Component Overlay Diagrams	12
B	Parts List	17

WARNING

Changes or modifications not expressly approved by RF Technology could void your authority to operate this equipment. Specifications may vary from those given in this document in accordance with requirements of local authorities. RF Technology equipment is subject to continual improvement and RF Technology reserves the right to change performance and specification without further notice.

1 Operating Instructions

The PA220 is part of the Eclipse range of modular base station equipment. It is a power amplifier capable of delivering 100 Watts in the VHF frequency range. It is designed to complement the T220 transmitter, and mounts in a standard Eclipse sub-rack.

1.1 Installation

There are no front panel controls. In normal circumstances no alignment or setup is required. If mounted in a sub-rack that has not previously been wired for a power amplifier, the rack connector must be wired according to the guidelines in section 1.1.1 below.

1.1.1 Sub-rack Wiring Guidelines

When installing an Eclipse Power Amplifier in an Eclipse sub-rack, observe the following guidelines for sub-rack installation:

- The sub-rack power supply must be capable of delivering the full current requirements for all modules fitted in the sub-rack, typically 20 Amperes for a 100W transmitter/amplifier.
- Owing to the current drain, power supply lines should be cabled to the power amplifier separately and using heavy gauge wire to minimise voltage drop and interference via the power supply of other modules in the rack.
- The ALC line from the power amplifier must be connected to the ALC input of the exciter. If this connection is not correctly made, no control of the output power level will be possible. This can result in excessive RF output power, and consequent breach of licensing authority regulations, or possible overload of the unit.

With an Eclipse T220, join pin 8(ALC) on the exciter and the amplifier.

1.2 Front Panel Indicators

PWR LED The power (PWR) LED shows that the dc supply is connected to the transmitter.

RFO LED The RF output (RFO) LED indicates that the amplifier is being driven and that the forward output power is above a preset level. This preset indication level is generally set 1 - 3 dB below the preset output power level. The presetting potentiometer RV2 is not accessible without removal of the cover plate.

TEMP LED The temperature (TEMP) LED indicates illuminates should the amplifier's internal temperature become too high. The RF power is automatically reduced if the internal temperature rises above safe limits.

1.3 Internal Adjustments

All internal adjustments are factory set and should not need to be changed under normal conditions. A possible exception to this is the RF output power level which may need to be changed to comply with local licensing requirements. The low forward power warning circuit should be set at the same time as the forward power level.

WARNING

Ensure that the power setting complies with the requirements of your licensing authority. Failure to do so may result in penalties being imposed by the licensing authority.

Output Power The output power is set by RV2. This is nominally set to 100 Watts (+50dBm), but may be set to any value between 20 and 100 Watts depending upon local regulations in the destination country. RV2 determines the threshold affecting the ALC voltage that is fed back to the transmitter module to regulate RF output power.

RF Level Detector The forward RF power threshold associated with the RFO LED on the amplifier front panel is set by RV3. This is nominally set at half to three-quarters of the preset output power.

1.4 Amplifier I/O Connections

The PA220 has three connectors on the rear panel.

1.4.1 RF Input

The RF drive is delivered via a BNC connector. The absolute maximum power that should be applied to this connector is 25 Watts.

1.4.2 RF Output

The RF output signal is available from an N-type connector.

Pins	Function
1, 2, 14, 15	Positive supply
12, 13, 24, 25	Ground (negative supply)
8	ALC output

Table 1: Pin connections for the 25 pin “D” connector on the rear panel

Note: The amplifier is capable of delivering as much as 120 Watts continuously. In certain conditions¹ an RF power of 130 Watts or more can be available via this connector. This corresponds to peak voltages in excess of 100 while currents in excess of 2 Amperes may flow. Appropriate care should be taken when working on the PA220 to avoid making or breaking connections when the amplifier is operating, and to avoid RF burns through close proximity to live connections, etc.

1.4.3 25 Pin Connector

The 25-pin “D” connector provides connection to ground and dc power, and from the automatic level control (ALC) circuit. The pin connections are given in table 1. The ALC line floats high to approximately 7Vdc. Pulling this line low will reduce output power. Voltages below 0.5V will reduce the output by more than 20dB. A pull-down current of approximately 1mA is required.

2 Circuit Description

The following descriptions should be read as an aid to understanding the block and schematic diagrams shown in figures 1 - 4.

¹Excessive powers may be available, for example, in the event of a failure of the ALC loop, such as may arise if the ALC feedback connection is broken.

2.1 Amplifiers

The RF power amplification is provided by two single transistor amplifiers, Q1 and Q2. Each amplifier is rated at 50 watts output. The input and output impedance of the transistors is matched to 50 Ω by broad band micro-strip matching networks.

Trimmer capacitors C10 and C24 are used on the input networks to optimize the input match at center of the desired frequency range. Similarly C58 and C59 on the output networks are used to optimize the output efficiency.

Since the design of the amplifiers allows them to be very broad band, they will not usually require re-adjustment unless changing frequency from one end of the band to the other.

The dc supply is fed to the amplifiers through resistors R27 and R28. This allows the collector current of each amplifier to be measured at the test socket.

2.2 Power Splitter / Combiners

In the 100W models, zero-degree hybrid power splitter / combiners are used to parallel the two amplifier stages. The hybrids consist of quarter-wave 70 Ω transmission lines and 100 Ω RF resistors CX1-4, R9 and R10. This configuration provides wider bandwidth and better balance than lower cost 90-degree hybrids.

2.3 Directional Coupler

The forward and reverse power components are measured through a coupled line directional coupler. The output of the coupled line is frequency compensated by R13, R14, C29 and C30 before being detected by D1 and D2.

The output of the detectors is proportional to the forward and reflected voltage components.

2.4 Low Pass Filter

A low pass filter consisting of L12 - 14 and C39 - 42 reduces the harmonic components to less than -80dBc. The filter uses a combination of lumped elements and printed microstrips to obtain the required harmonic attenuation.

2.5 Power Control Circuits

The forward and reverse voltages from the directional coupler are amplified and inverted by U1a and U1b. The amplified voltages are combined before connecting to the input of error amplifier U1d.

Error amplifier U1d compares the detected voltage with the dc reference voltage from output power trimpot RV1. The amplified difference at the output of U1d is supplied to the rear panel system connector for connection to the T220 ALC input.

Equipment Type	Key Specifications
Power Supply	13.8Vdc,15A
RF Source	25 Watt (eg. T220 exciter)
RF Load / Attenuator	50Ω, 50/100W, SWR<1.2:1
RF Power Meter	eg. HP437B or calibrated detector and voltmeter

Table 2: Standard test equipment for the PA220 Power Amplifier

2.6 RF Output Indicator

The forward power voltage is compared with the pre-set dc reference voltage from RV2 by U1c. The output of U1c is used to turn on the RFO LED and provide an output power logic signal to the test connector.

RV2 is normally set so that the RFO LED comes ON 1 - 3db below the nominal power output level.

2.7 Over Temperature Protection

Thermistor RT1 is mounted to the case of output transistor Q1. If the transistor case temperature rises above 90 Celsius the resistance of RT1 increases and Q5 is turned ON.

This causes the TEMP LED to come on and also reduces the dc reference voltage to the output power error amplifier U1d. The input power will then be reduced by the transmitter ALC circuits and the output transistor is kept within safe operating limits.

3 Field Alignment Procedures

3.1 Output Power Level

1. Set the unit up on a bench with the standard test equipment listed in table 2.
2. Set RV1 and RV2 both fully counter-clockwise.
3. Set the exciter to the desired operating frequency.

4. Adjust RV1 to set the output power on the meter to the level at which you want the RFO LED to illuminate.
5. Adjust RV2 until the RFO LED just goes out.
6. Adjust RV1 for the desired output power.

3.2 Tuning Procedure

Adjustment of the matching circuits is carried out with the aim of

- ensuring that the specified power is available
- balancing the load reasonably equally between the power transistors, and
- obtaining acceptable efficiency in the power transistors.

Note that the factory alignment procedure is complicated, but allows a given unit to operate across a full 10% bandwidth, without further adjustment. Alignment without appropriate equipment can leave the amplifier unstable or otherwise unable to meet specification. However, the procedure below will usually provide adequate performance.

1. Disconnect the ALC line.
2. Set the RF source to deliver 15W at the highest frequency in the band over which the PA is specified.
3. Measuring the RF output power, adjust C10, C24, C102, C112, C58, C59, C104 and C114 to obtain maximum output.
4. Measuring the collector currents of Q1 and Q2 at the test socket, adjust C58 and C59 to reduce and balance the currents, but keeping the power above the required level.
5. Proceed to carry out the power setting procedure in section 3.1.

4 Specifications

4.1 Description

The PA220 power amplifiers are designed for use with the T220 series transmitters to provide 100 Watts of RF output. Output power is regulated by connecting the ALC output to the ALC input of the driving exciter. The drive from the transmitter module is then automatically adjusted to maintain the required output.

The regulated power level can be preset over a wide guaranteed range from 25 to 100 Watts or more, depending on the available input power and the model.

Sensing circuits are provided to protect the output transistors from excessive temperature. If the heat sink temperature rises to 80C, the input drive will be reduced to prevent damage.

4.2 Physical Configuration

The power amplifier is designed to fit in an RF Technology sub-rack within a 19" rack frame. The installed height is 4 Rack Units (RU), or 178mm, and the depth is 350mm. The amplifier is 95.25mm or three Eclipse units wide. The amplifier uses an extruded aluminium heat sink with vertical fins. Heatsink temperature rise is typically 20C at 50W output.

4.3 Front Panel Indicators and Test Points

4.3.1 Indicators

Power: Green LED

RF Power: Yellow LED

Over Temperature: Red LED

4.3.2 Test Points

Forward Power: Voltage to ground, 0 - 4V, uncalibrated (pin 4 - gnd)

Reverse Power: Voltage to ground, 0 - 4V, uncalibrated (pin 3 - gnd)

Collector Currents: Voltage to positive supply, across 0.1 Ω , $\pm 10\%$ (pins 7 - 1 and 8 - 1).

4.4 Electrical Specifications

4.4.1 Power Requirements

Operating Voltage: 10.5 - 16 Volts, with output power reduced below 12.5V

Current Drain: 16 Amperes maximum (14 typical) at 100 Watts and 13.5 Volts, 100mA maximum standby

Polarity: Negative Ground

4.4.2 Frequency Range

Model	Frequency Range
PA220	215-240MHz

4.5 Antenna Impedance

Nominal load impedance is 50Ω SWR 1.5:1 or better. The PA220 will operate with a VSWR of 2:1 at all phase angles. The forward power will reduce as reverse power rises above acceptable limits, typically at an SWR of about 2.5:1.

4.6 Output Power

Nominally 100 Watts, preset adjustable from 25 to 100. Gain is typically >5dB.

4.6.1 Transmit Duty Cycle

The transmitter is rated for 100% duty cycle (continuous operation) at 50W output for air temperature below 40C. Derate linearly above 40C to 50% at 60C.

The transmitter is rated for 50% duty cycle at 100W output for air temperature below 40C. Derate linearly above 40C to 5% at 70C.

4.7 Spurious and Harmonics

Less than $1\mu\text{W}$ at any harmonic of the transmit frequency.

4.8 Heatsink Temperature

The heatsink temperature can rise to 80C without affecting operation, except for derating based on air-temperature as noted in section 4.6.1 above. Shutdown will occur at heatsink temperatures exceeding approximately 90C.

4.9 ALC Output

The ALC is intended for connection to the T220. It supplies a voltage which decreases with increasing power or temperature. Voltages below 6V should reduce drive power, at a rate of approximately 6~dB/Volt, with voltages below 1V producing a minimum of 25~dB attenuation.

4.10 Connectors

4.10.1 RF Input

The RF drive is delivered via a BNC connector. The maximum power that should be applied to this connector is 32 Watts.

4.10.2 RF Output

The RF output signal is available from an N-type connector.

4.10.3 25-Pin Connector

A 25-pin, D-shell “D” connector is mounted on the rear panel. It provides power connections and a connection from the automatic level control (ALC) circuit. The pin connections are given in table 1.

4.10.4 9-Pin Connector

A front-panel, 9-pin, D-shell connector provides analogue voltages for testing purposes.

A Engineering Diagrams

A.1 Block Diagram

Figure 1 shows the block signal flow diagram of the PA220 amplifier. Figure 2 shows the chassis wiring diagram of the PA220 amplifier.

A.2 Circuit Diagrams

Figure 3 shows the detailed circuit diagram of the amplifier with component numbers and values.

A.3 Component Overlay Diagrams

Figure 5 shows the PCB overlay guides for the amplifier with component positions.

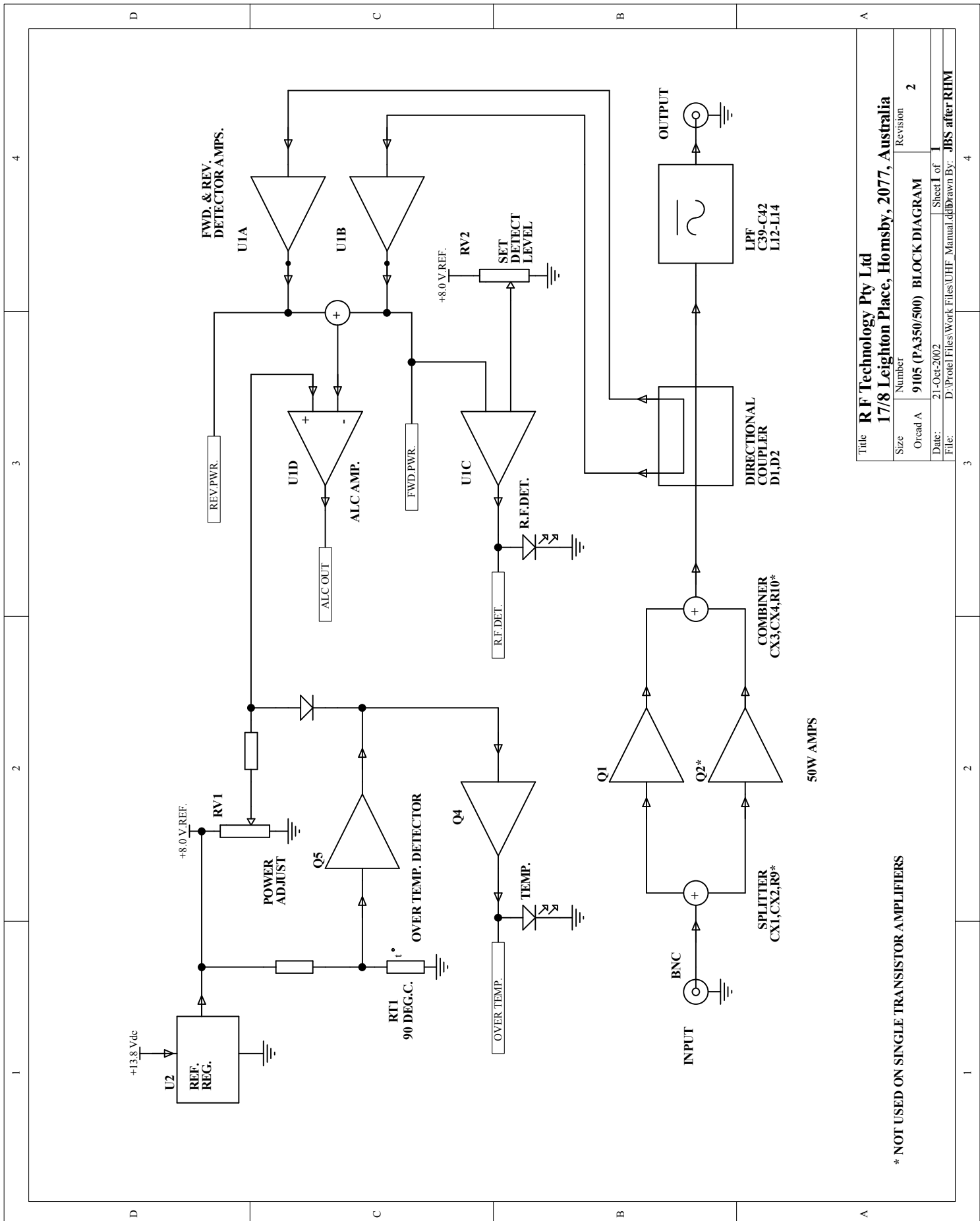

* NOT USED ON SINGLE TRANSISTOR AMPLIFIERS

Title		R F Technology Pty Ltd	
Size		17/8 Leighton Place, Homsby, 2077, Australia	
Sheet Number	9105 (PA350/500)	Block Diagram	Revision 2
Date:	21-Oct-2002	Sheet 1 of 1	
File:	D:\Protel Files\Work Files\UHF_Manual.dtb Drawn By: JBS after RHM		

4

3

2

1

4

3

2

1

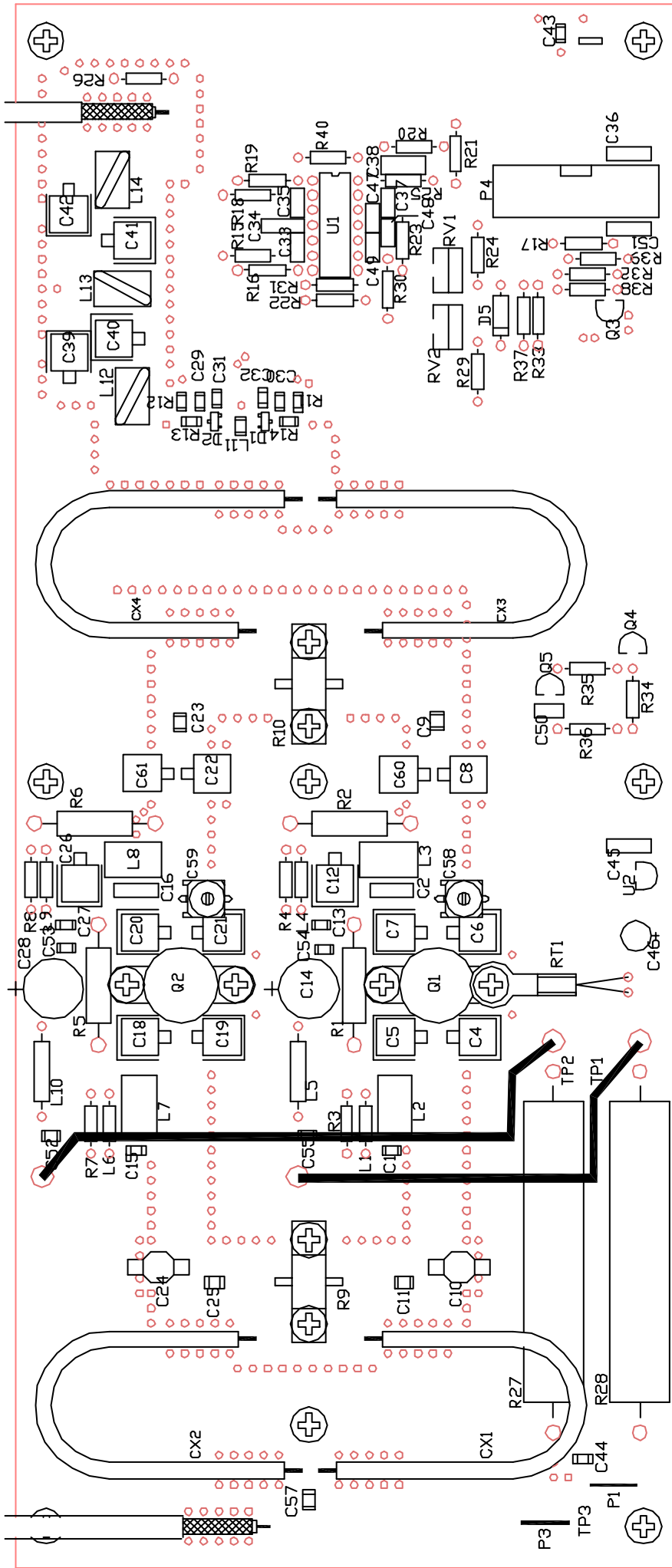

9105 2Q Overlay Drawing

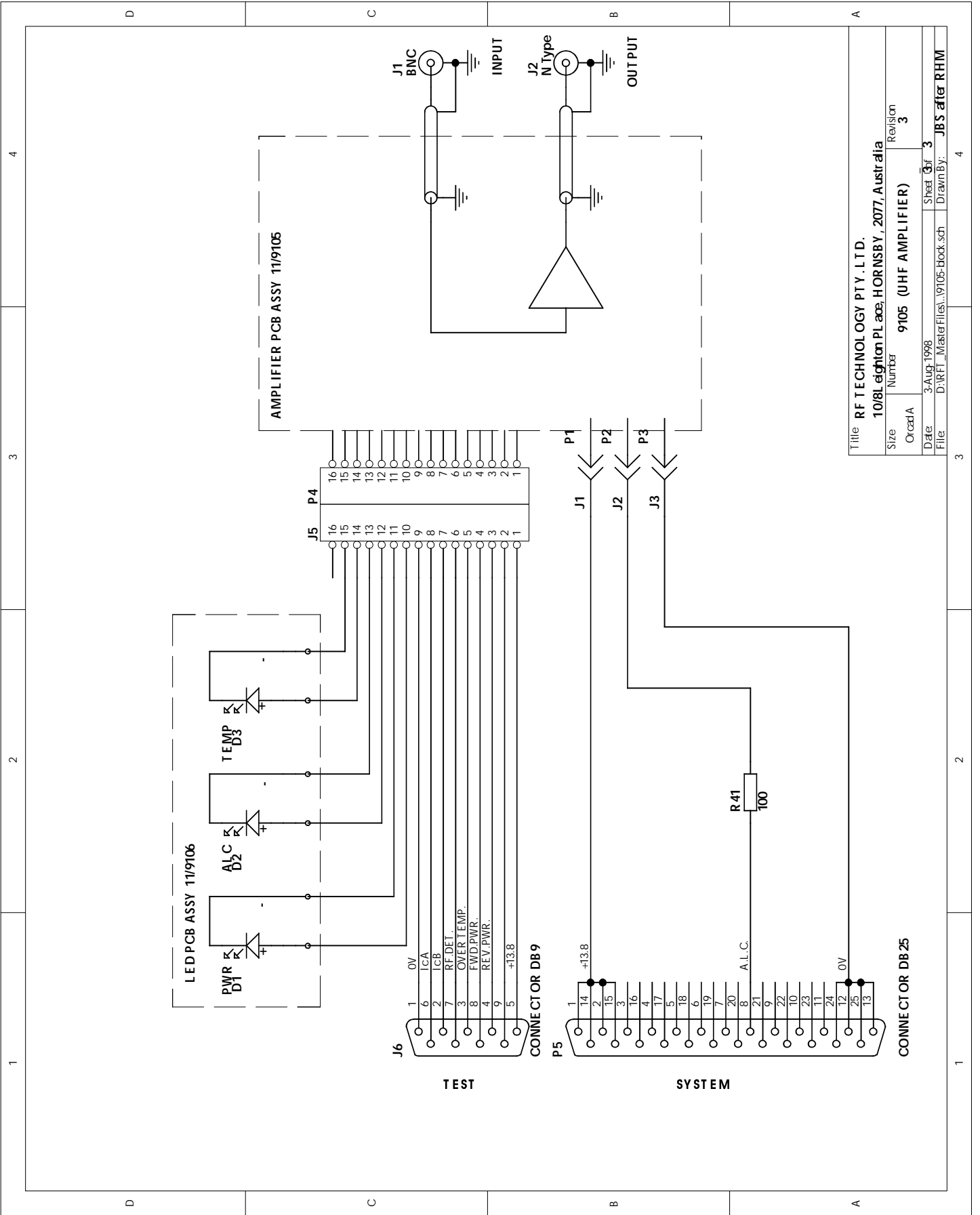

Title			
RF TECHNOLOGY PTY. LTD.			
10/8L eighton PL ace, HORNSBY, 2077, Australia			
Size	Number	Revision	
Orca/A	9105 (UHF AMPLIFIER)	3	
Date:	3-Aug-1998	Sheet	3 of 3
File:	D:\RFT_MasterFiles\19105-board.sch		Drawn By: JBS after RHM

B PA220 Parts List

B.1 PA220 (05/9105/0220)

Ref.	Description	Part Number
C1	Capacitor 1N0 5% 63V NPO SM1203	46/3300/01N0
C4	Capacitor 56pF 5% 250V MC Mica	48/3002/056P
C5	Capacitor 56pF 5% 250V MC Mica	48/3002/056P
C6	Capacitor 56pF 5% 250V MC Mica	48/3002/056P
C7	Capacitor 47pF 5% 250V MC Mica	48/3002/047P
C8	Capacitor 27pF 5% 250V MC Mica	48/3002/027P
C9	Capacitor 220pF 20% 100v SM1008	46/3100/220P
C10	Capacitor Trim 2-18pF Hi Temp	49/3001/018P
C11	Capacitor 220pF 20% 100V SM1008	46/3100/220P
C12	Capacitor 91pF 5% 250V MC Mica	48/3002/091P
C13	Capacitor 1N0 5% 63V NPO SM1206	46/3300/01N0
C14	Capacitor 6.8uF 20% 25V	41/2225/06U8
C15	Capacitor 1N0 5% 63V NPO SM1206	46/3300/01N0
C18	Capacitor 56pF 5% 250V MC Mica	48/3002/056P
C19	Capacitor 56pF 5% 250V MC Mica	48/3002/056P
C20	Capacitor 56pF 5% 250V MC Mica	48/3002/056P
C21	Capacitor 47pF 5% 250V MC Mica	48/3002/047P
C22	Capacitor 27pF 5% 250V MC Mica	48/3002/027P
C23	Capacitor 220pF 20% 100V SM1008	46/3100/220P
C24	Capacitor Trim 2-18pF Hi Temp	49/3001/018P
C25	Capacitor 220pF 20% 100V SM1008	46/3100/220P
C26	Capacitor 91uF 5% 250V MC Mica	48/3002/091P
C27	Capacitor 1N0 5% 63V NPO SM1206	46/3300/01N0
C28	Capacitor 6.8uF 20% 25V	41/2225/06U8
C29	Capacitor 10pF 5% 63V NPO SM1206	46/3300/010P
C30	Capacitor 10pF 5% 63V NPO SM1206	46/3300/010P
C31	Capacitor 100pF 5% 63V NPO SM1206	46/3300/100P
C32	Capacitor 100pF 5% 63V NPO SM1206	46/3300/100P
C33	Capacitor 27pF 2% 100V NPO Rad	45/2680/027P
C34	Capacitor 1N0 5% 63V NPO SM1206	46/3300/01N0
C35	Capacitor 27pF 2% 100V NPO Rad	45/2680/027P
C36	Capacitor 10nF 10% 50V X7R Rad	46/2001/010N
C37	Capacitor 27pF 2% 100V NPO Rad	45/2680/027P
C38	Capacitor 100nF 5% 50V NKT Rad	47/2007/100N
C39	Capacitor Soshin 12pF Mica SM1210	48/3003/012P
C40	Capacitor Soshin 27pF Mica SM1210	48/3003/027P
C41	Capacitor Soshin 27pF Mica SM1210	48/3003/027P
C42	Capacitor Soshin 12pF Mica SM1210	48/3003/012P
C43	Capacitor 1N0 5% 63V NPO SM1206	46/3300/01N0
C44	Capacitor 1N0 5% 63V NPO SM1206	46/3300/01N0
C45	Capacitor 100nF 10% 50V X7R Rad	46/2001/100N
C46	Capacitor 10uF 35V Electro Rad	41/2001/010U
C47	Capacitor 27pF 2% 100V NPO Rad	45/2680/027P
C48	Capacitor 27pF 2% 100V NPO Rad	45/2680/027P
C49	Capacitor 27pF 2% 100V NPO Rad	45/2680/027P
C50	Capacitor 27pF 2% 100V NPO Rad	45/2680/027P
C51	Capacitor 10nF 10% 50V X7R Rad	46/2001/010N
C52	Capacitor 1N0 5% 63V NPO SM1206	46/3300/01N0
C53	Capacitor 100N 10% 63V X7R SM1206	46/3310/100N
C54	Capacitor 100N 10% 63V X7R SM1206	46/3310/100N
C55	Capacitor 1N0 5% 63V NPO SM1206	46/3300/01N0
C56	Capacitor 56pF 5% 250V Mica	48/3002/056P
C57	Capacitor 220pF 20% 100V SM1008	46/3100/220P
C58	Capacitor 47pF 5% 250V Mica	48/3002/027P
C58A	Capacitor Trim 2-18pF Hi Temp	49/3001/018P
C59	Capacitor 47pF 5% 250V Mica	48/3002/027P

Ref.	Description	Part Number
C59A	Capacitor Trim 2-18pF Hi Temp	49/3001/018P
C60	Capacitor Trim 2-18pF Hi Temp	49/3001/018P
C61	Capacitor Trim 2-18pF Hi Temp	49/3001/018P
C102	Capacitor Trim 6-100pF Hi Temp	493003/100P
C112	Capacitor Trim 6-100pF Hi Temp	49/3003/100P
CX1	RFT Coaxial Cable, 235mm/RG179	12/0021/0235
CX2	RFT Coaxial Cable, 235mm/RG179	12/0021/0235
CX3	RFT Coaxial Cable, 235mm/RG179	12/0021/0235
CX4	RFT Coaxial Cable, 235mm/RG179	12/0021/0235
D1	Diode BAT17 SOT-23	21/3030/0017
D2	Diode BAT17 SOT-23	21/3030/0017
D5	Diode 1N4148	21/1010/4148
L1	Inductor 1uH Axial	37/2021/001U
L2	Moulded Inductor, 7.5 Turns	37/2021/0007
L3	Moulded Inductor, 7.5 Turns	37/2021/0007
L4	Ferrite Bead	37/1022/0001
L5	6 Hole Choke	37/1021/0001
L6	Inductor 1uH Axial	37/2021/001U
L7	Moulded Inductor, 7.5 Turns	37/2021/0007
L8	Moulded Inductor, 7.5 Turns	37/2021/0007
L9	Ferrite Bead	37/1022/0001
L10	6 Hole Choke	37/1021/0001
L11	Inductor 1uH 10% SM1008	37/3320/01U0
L12	2.5T	37/2635/0002
L13	2.5T	37/2635/0002
L14	2.5T	37/2635/0002
P1	6.35 QC Tab	35/0635/0001
P3	6.35 QC Tab	35/0635/0001
P4	16 Way Shrouded Header	35/2502/0016
Q1	Transistor RF Power MRF650	27/3020/MRF650
Q2	Transistor RF Power MRF650	27/3020/MRF650
Q3	Transistor NPN 2N3904 T0-92	27/2020/3904
Q4	Transistor PNP 2N3906 T0-92	27/2010/3906
Q5	Transistor NPN 2N3904 T0-92	27/2020/3904
R3	Resistor 10R 5% .25W Axial	51/1040/0010
R4	Resistor 10R 5% .25W Axial	51/1040/0010
R7	Resistor 10R 5% .25W Axial	51/1040/0010
R8	Resistor 10R 5% .25W Axial	51/1040/0010
R9	Resistor 100 Ohm Non Inductive	51/RF40/0100
R10	Resistor 100 Ohm Non Inductive	51/RF40/0100
R11	Resistor 220R 5% .25W SM1206	51/3380/0220
R12	Resistor 220R 5% .25W SM1206	51/3380/0220
R13	Resistor 220R 5% .25W SM1206	51/3380/0220
R14	Resistor 220R 5% .25W SM1206	51/3380/0220
R15	Resistor 47K 5% .25 Axial	51/1040/047K
R16	Resistor 100K 5% .25W Axial	51/1040/100K
R17	Resistor 1K 5% .25W Axial	51/1040/01K0
R18	Resistor 47K 5% .25 Axial	51/1040/047K
R19	Resistor 100K 5% .25W Axial	51/1040/100K
R20	Resistor 1K 5% .25W Axial	51/1040/01K0
R21	Resistor 100R 5% .25W Axial	51/1040/0100
R22	Resistor 33K 5% .25W Axial	51/1040/033K
R23	Resistor 47K 5% .25W Axial	51/1040/047K
R24	Resistor 10K 5% .25W Axial	51/1040/010K
R25	Resistor M1 5% .25W Axial	51/1040/01M0
R26	Resistor 100K 5% .25W Axial	51/1040/100K
R27	Resistor 0R1 WW 10W	51/0010/00R1
R28	Resistor 0R1 WW 10W	51/0010/00R1
R29	Resistor 10K 5% .25W Axial	51/1040/010K
R30	Resistor 10K 5% .25W Axial	51/1040/010K
R31	Resistor 10K 5% .25W Axial	51/1040/010K

PA220 PARTS LIST

Ref	Description	Part Number
R32	Resistor 270R 5% .25W Axial	51/1040/0270
R33	Resistor 270R 5% .25W Axial	51/1040/0270
R34	Resistor 10K 5% .25W Axial	51/1040/010K
R35	Resistor 2K2 5% .25W Axial	51/1040/02K2
R36	Resistor 10K 5% .25W Axial	51/1040/010K
R37	Resistor 10K 5% .25W Axial	51/1040/010K
R38	Resistor 10K 5% .25W Axial	51/1040/010K
R39	Resistor 680R 5% .25W Axial	51/1040/0680
R40	Resistor 33K 5% .25W Axial	51/1040/033K
R41(P2)	Resistor 100R 5% .25W Axial	51/1040/0100
RT1	Thermistor	54/0400/0080
RV1	10K Trimpot	53/1020/010K
RV2	10K Trimpot	53/1020/010K
U1	IC Quad Op-Amp TLC274	25/2050/274C
U2	IC Voltage Reg LM78L08	25/2040/78L08
Assembly 11/9106/0001		
	PCB PA LED	30/9106/0001
D1	Diode LED Green T1 3/4	21/1011/LEDG
D2	Diode LED Red T1 3/4	21/1011/LEDR
D3	Diode LED Yellow T1 3/4	21/1011/LEDY
Assembly 12/0004/0001		
	Connector 16 way IDC	35/2512/0016
	Cable 16 way 26GA .05ID	36/1000/0016
	Connector DB9F IDC	35/5020/009F
	Connector DB25M Solder	35/5020/024M
	Spacer M3 x 10	73/M3SP/H010
	Screw M3 x 6 CSK PD BZNK	70/M315/0006
	Nut M3 Steel BZNK	72/M315/0001
	Washer M3 Shakeproof Steel BZNK	71/M325/0001
	Screw M3 x 6 TT PNHD BZNK	70/M355/0006
	Screw M3 x 10 TT PNHD PD BZNK	70/M355/0010
	Spacer A1 5D x 3L M3 Clear	73/M3SP/0003
Assembly 12/0005/0075		
	Connector N Type Flange Mount	35/50NA/0001
	Cable Coax RG316	35/0030/0316
Assembly 12/0006/0320		
	Connector BNC Crimp	35/50BA/0001
	Cable Coax	36/0030/0316
Assembly 12/0007/R370		
	Wire 50 x .25 T/C PVC Red	36/50X2/RED
	QC 6.35 F Crimp	35/1635/0001
Assembly 12/0007/B340		
	Wire 50 x .25 T/C PVC Black	36/50X2/BLK
	QC 6.35 F Crimp	35/1635/0001
	Bottom, Power Amp	80/9127/0001
	Top, Power Amp	80/9126/0001
	Rear Panel, Power Amp	80/9125/0001
	Front sub Panel, Power Amp	80/9128/0001
	Front Panel, Power Amp	80/9129/0001
	Heat Sink, Power Amp	80/9130/0001
	Cover Plain Module	80/9101/0001
	Pawl Latch, DIUS DP109SAC	76/0001/0001
	Handle 3.0	76/0002/300B
	Handle Ferrule .156Blk	76/003/156B

Ref	Description	Part Number
	Screw 4-40 x 6 CSK PD BZNK	70/4415/0006
	Label, PA Front Panel	81/9105/0001
	Label, S/W and SMA	81/9100/PA220
	Gnd Lug M3 Utilux H254	39/M301/H254

D

D

C

C

B

B

A

A

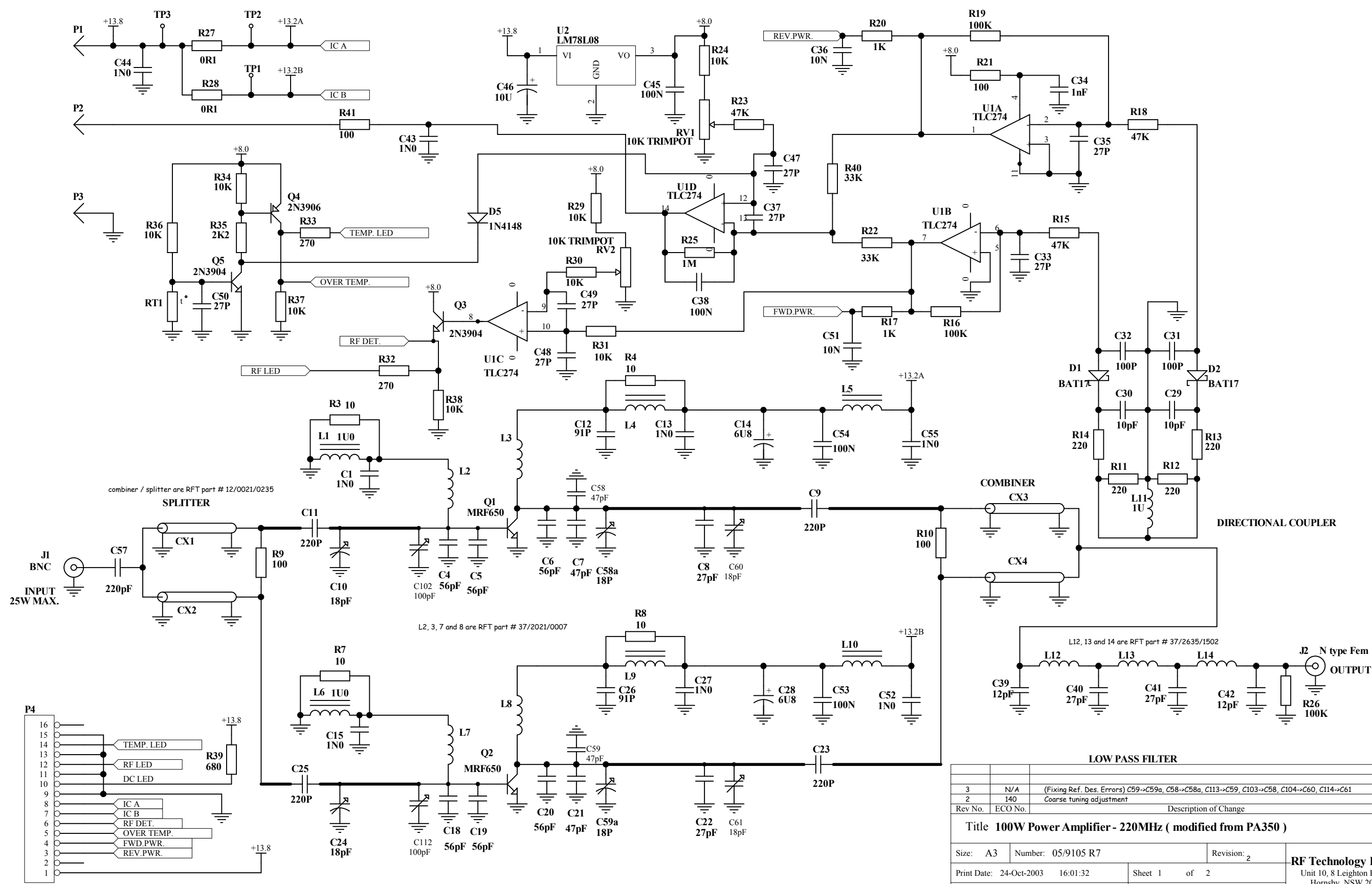

LOW PASS FILTER		
Rev No.	ECO No.	Description of Change
3	N/A	(Fixing Ref. Des. Errors) C59->C59a, C58->C58a, C113->C59, C103->C58, C104->C60, C114->C61
2	140	Coarse tuning adjustment
Title 100W Power Amplifier - 220MHz (modified from PA350)		
Size: A3	Number: 05/9105 R7	Revision: 2
Print Date: 24-Oct-2003 16:01:32	Sheet 1 of 2	RF Technology Pty Ltd Unit 10, 8 Leighton Place Hornsby, NSW 2077 Australia
Rev. Release Date:	Originator: GM	
File: \\Goanna\master\CAD_File\Prote99\220MHz\220MHz.ddb - PA220-Rev3.sch		