

ZETRON 827 MPT TO ECLIPSE REPEATER

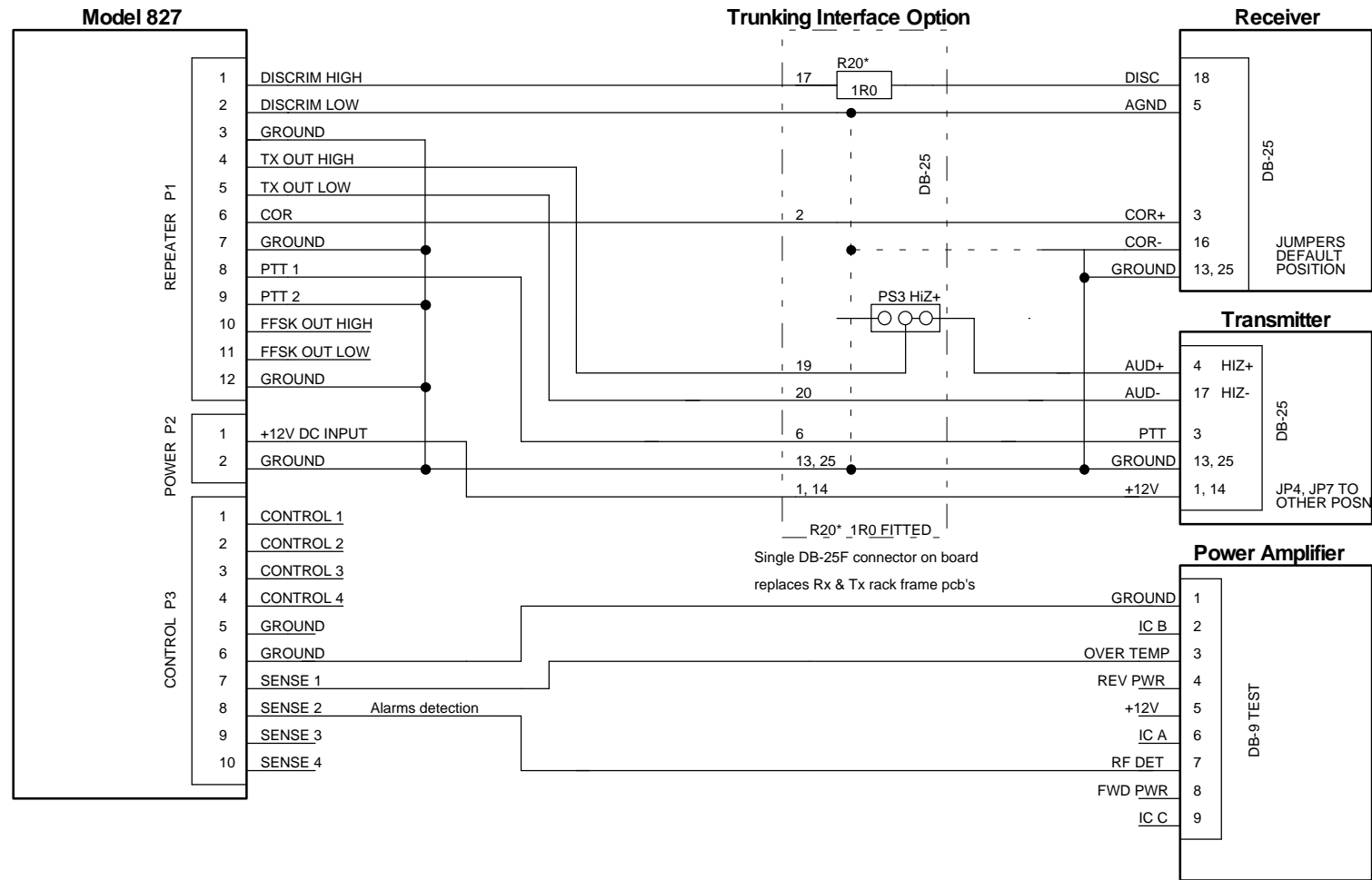

NOTES

- CONTACT CLOSURE OF PTT LINE TO GROUND KEYS UP THE TRANSMITTER
- TRANSMITTER AUDIO - SET FLAT RESPONSE
- TRANSMITTER FFSK - SET FLAT RESPONSE
- COMBINE TRANSMITTER AUDIO AND FFSK SIGNALS
- DISCRIMINATOR INPUT - SET FLAT RESPONSE
- EXTERNAL COR INPUT. LOW=CARRIER

ZETRON 827 MPT CONTOLLER

- SET JUMPER JP3 ON POSITION A: NORMALLY OPEN
SET JP5 ON POSITION B: TX FLAT INPUT
SET JP11 ON POSITION A: TX FLAT INPUT
ADD A JUMPER TO POSITION C OF JP11
SET JP7 AND JP10 ON POSITION B: FLAT RESPONSE
SET JP6 ON POSITION B AND JP13 ON POSITION A

ECLIPSE

- TX: STANDARD
TX: SET JP4 AND JP7 TO NON STANDARD POSITION
TX: SET JP4 AND JP7 TO NON STANDARD POSITION
TX: SET JP4 AND JP7 TO NON STANDARD POSITION
RX: STANDARD
RX: CONNECT PIN 16 COR- TO GND

Title Zetron 827 - Eclipse		
Author GL RFT		
File C:\MYDOCU~1\CAD\ZETRON~2.DSN	Document	
Revision 1.0	Date 08 September 2003	Sheets 1 of 1